

PANZER German 3 Ton Aufsetzkran

PANZERCONCEPTS.COM

1/35 scale 35016
Designed to fit the Tamiya Opel Blitz 35291

When printing Instructions turn off "FIT TO PAGE" in your Print Settings

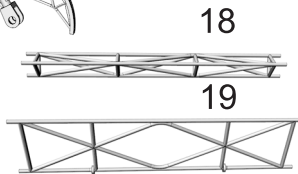
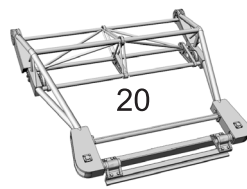
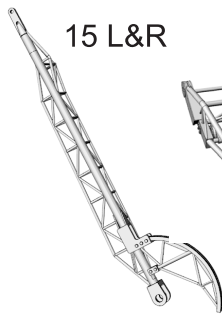
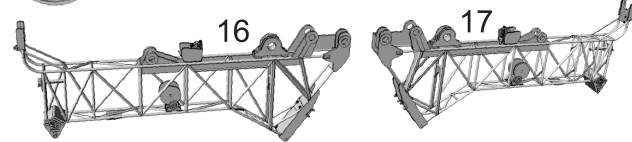
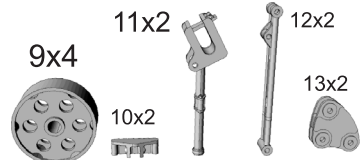
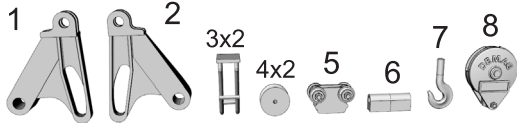

I do try to get all resin removed from holes but if there is any residue you may have to open them up. Here are the hole/drill size for the included Rods/Tubes

- .7mm (.0325) Rod (Brass)
- 1.4mm (.055) Rod
- 2mm (.082) Tube
- 2.5mm (.1) Tube
- 3mm (.125) Tube

For my USA Friends Harbor Freight and/or Amazon has some inexpensive Wire Gauge Machinist drill sets #1-60 which are great for model building I have been using my set for many years now.

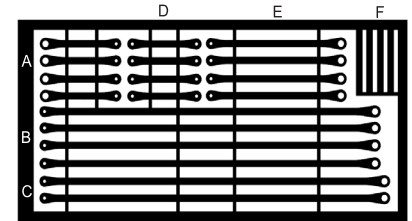

1

Make both sides (2&17) do not glue Part 1

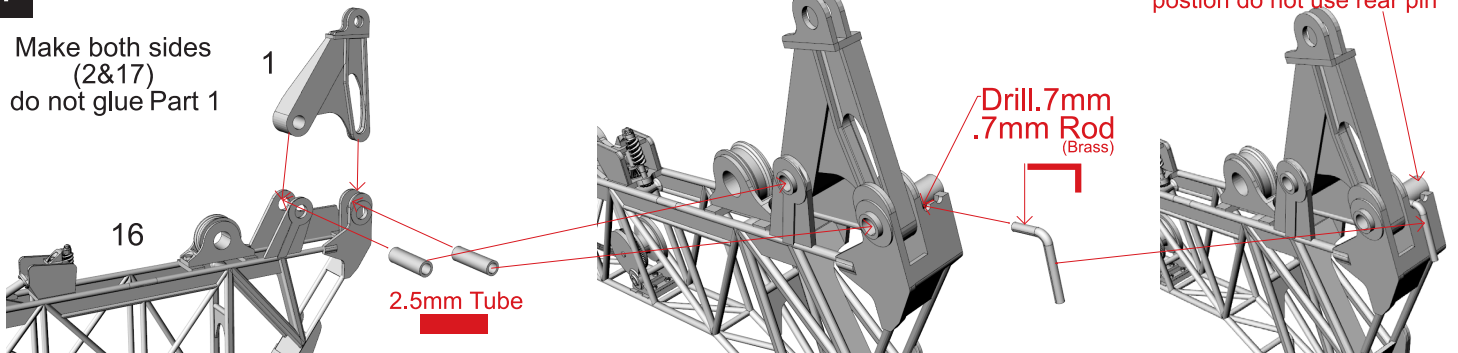

2

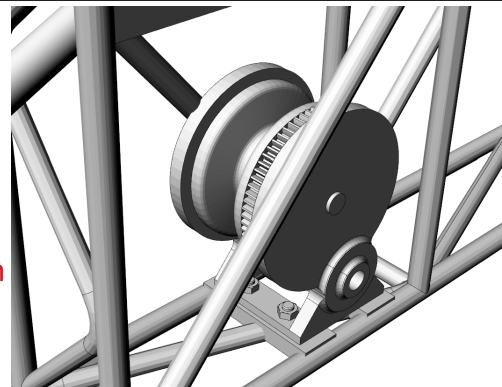
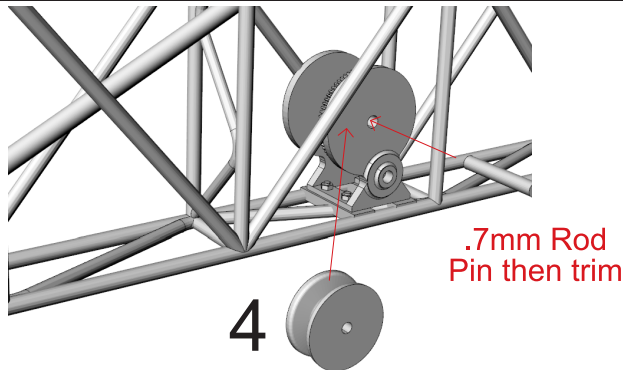

3

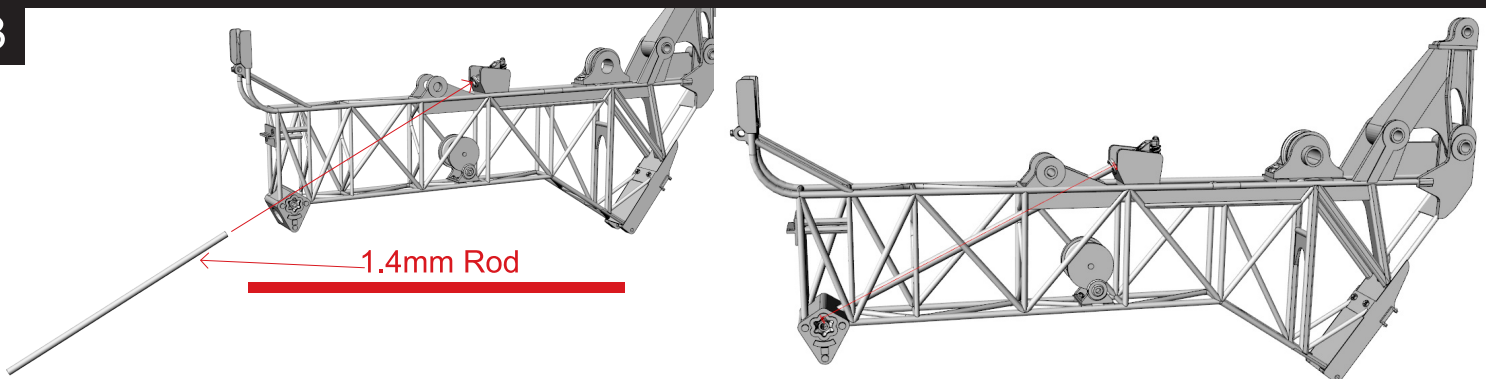

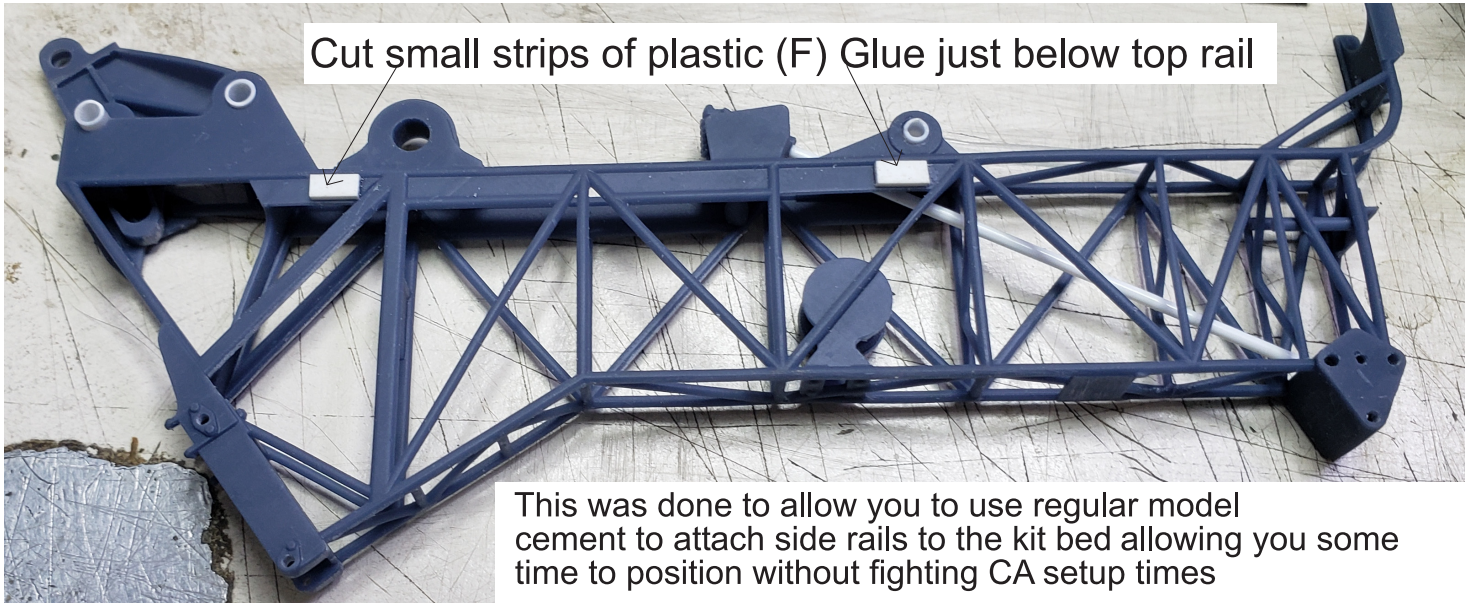

Build your Frame and bed according to the Plastic kit Instructions For the Tamiya kit. In Step 7 do not use the spare tire. Step 18 Jerry Can Rack

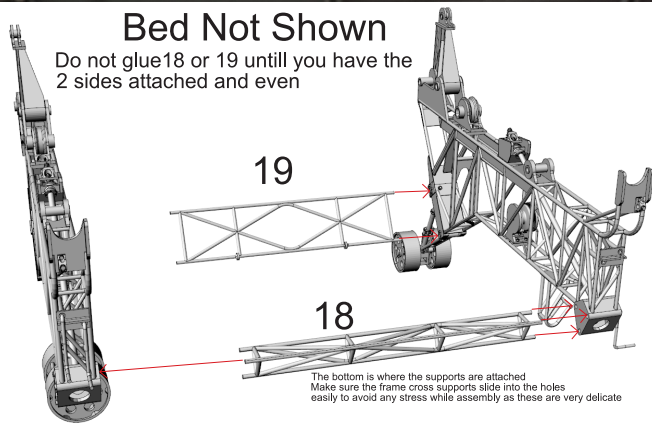
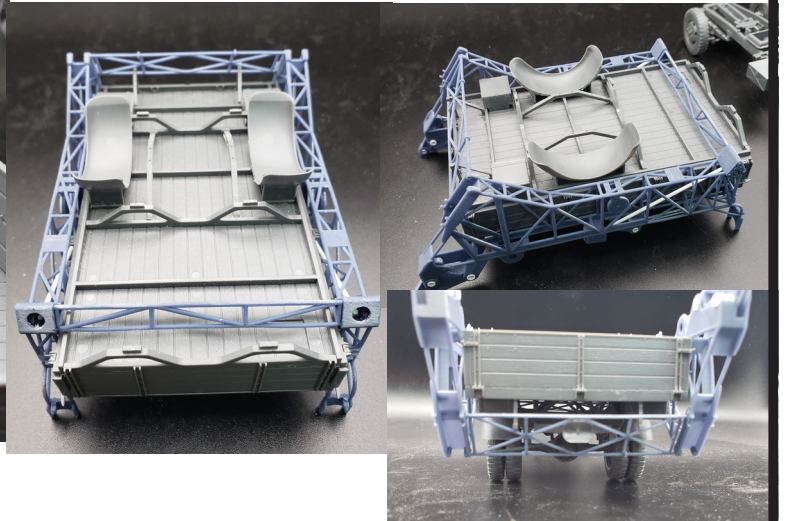
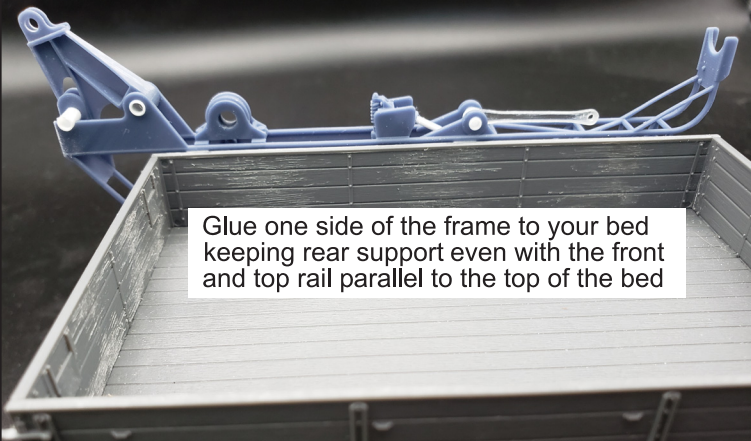

Bed Not Shown

Do not glue 18 or 19 until you have the 2 sides attached and even

Slide .7mm brass rod through mounts Once everything is square glue all into the final position

For extra Details make small z Bracket from scrap brass or foil tape over the bed. Not sure how many were used down the sides No clear photos besides this.

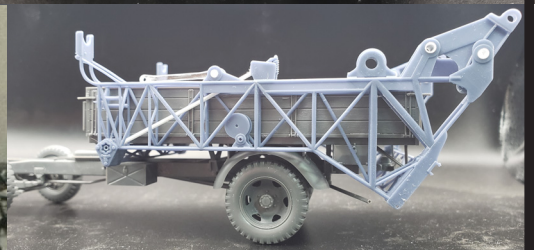
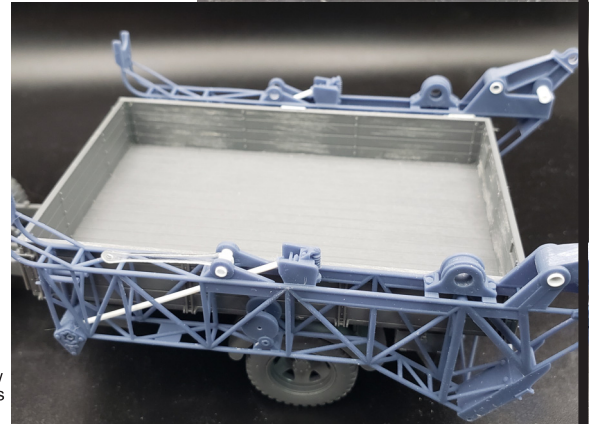
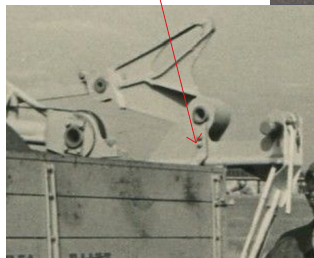
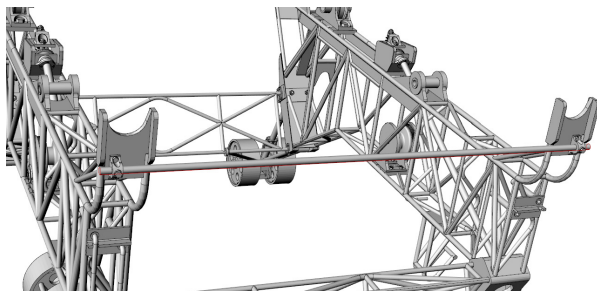

5

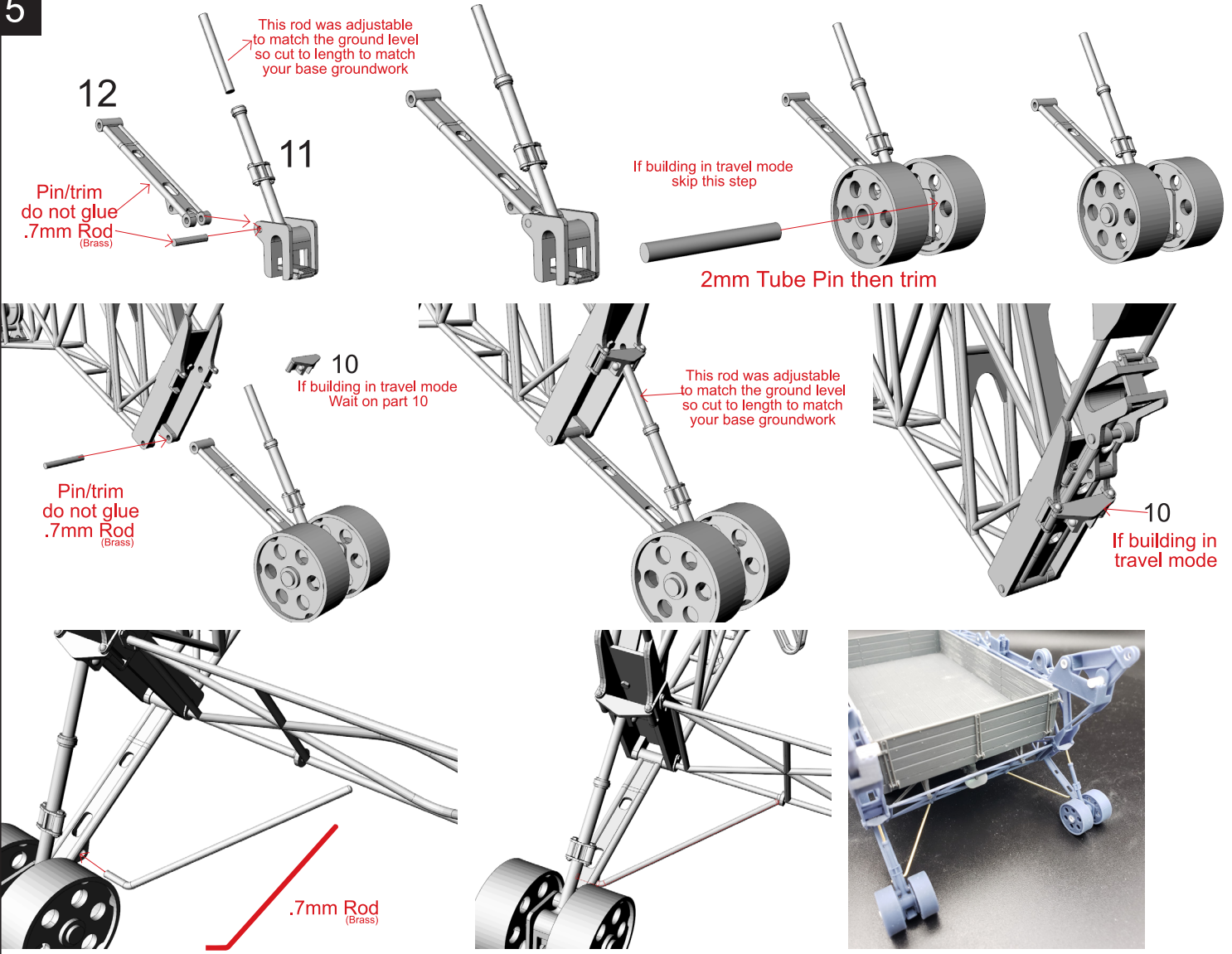

6

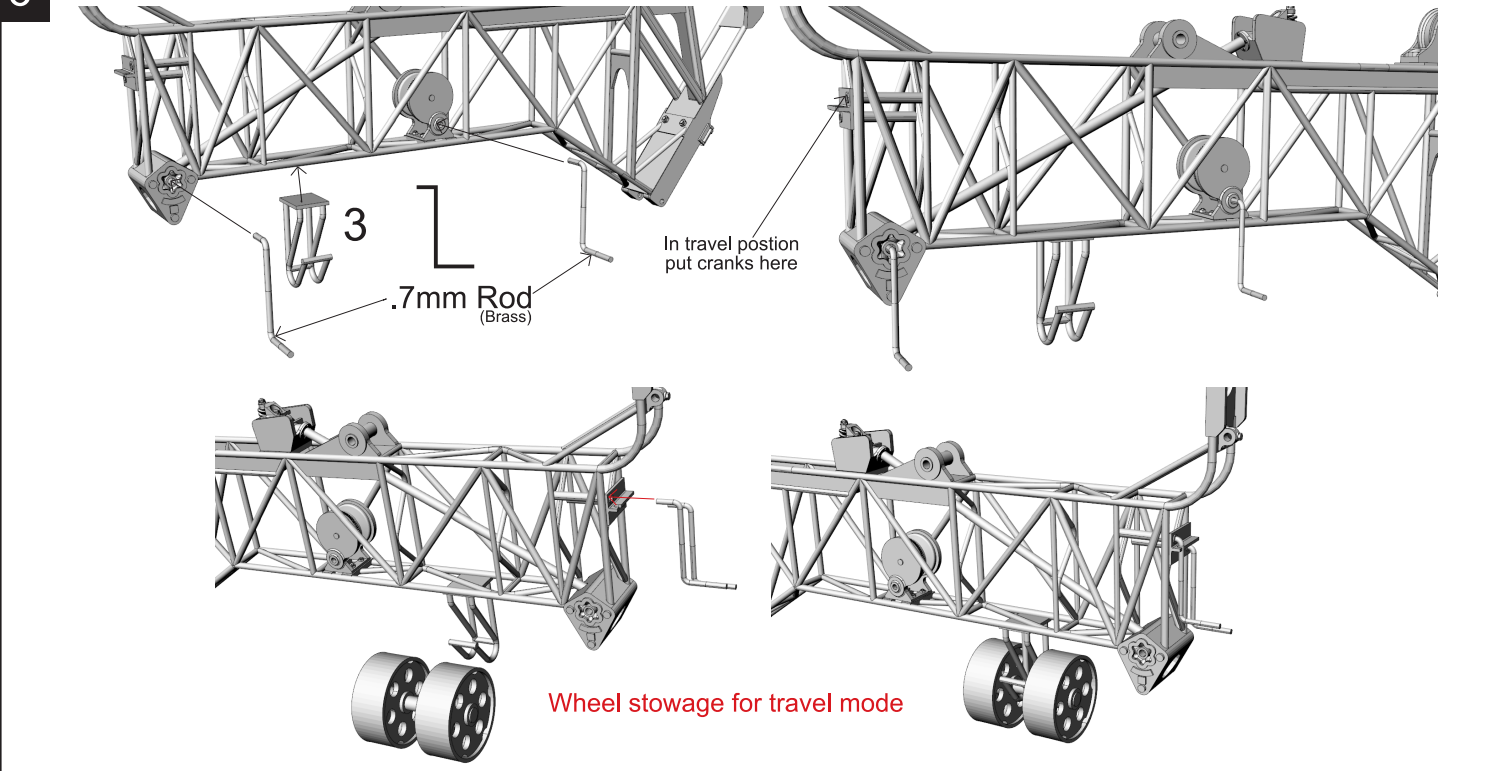

7

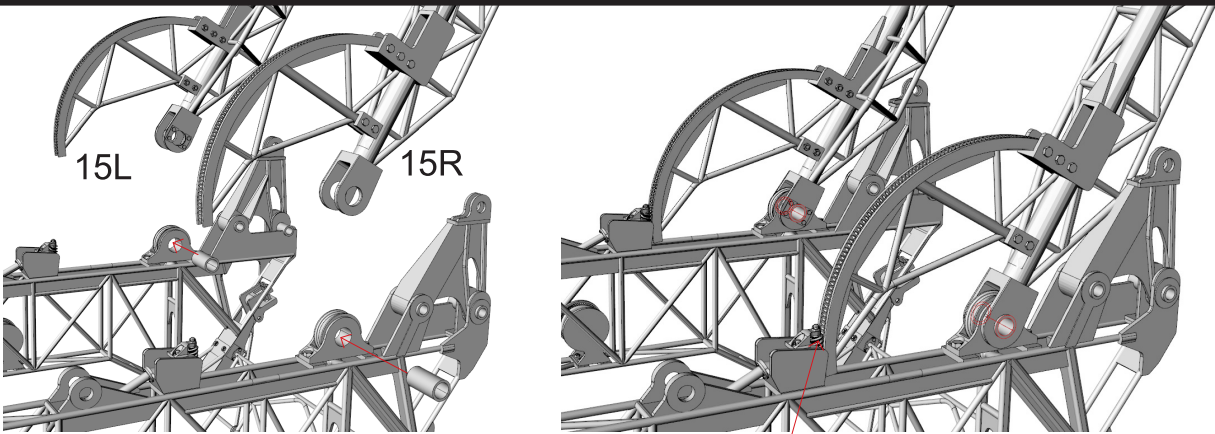

3mm Tube pin/trim Parts 15 will lock into the side frame worm gear allowing you to position the uprights in any position

1.4mm Rod

Slide rod through one upright then through part 6 then the other leave rod long for now and do not glue

Round/sand one end of 1.4mm rod

Slip both rods into Part 6 then into parts 15 Glue to part 15 center on top rod then glue Still leaving top rod loose in part 15

Do not glue yet

Do not glue yet

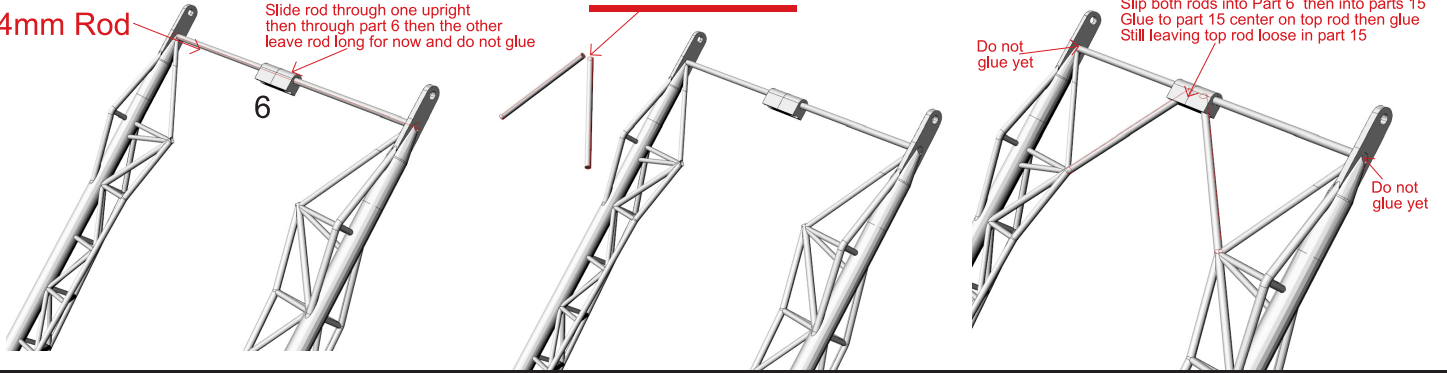

8

Insert this side first

20

Insert this side first

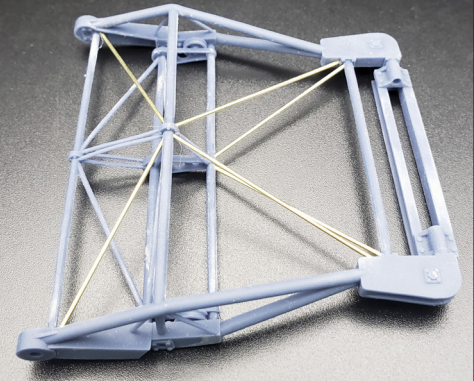
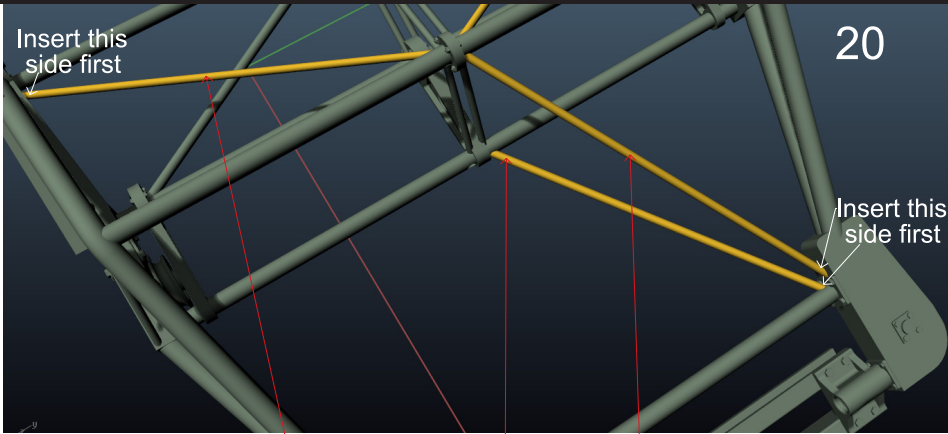

2x each .7mm Rod (Brass)

carefully slide brass rod into holes on part 20 once all are in place then glue

9

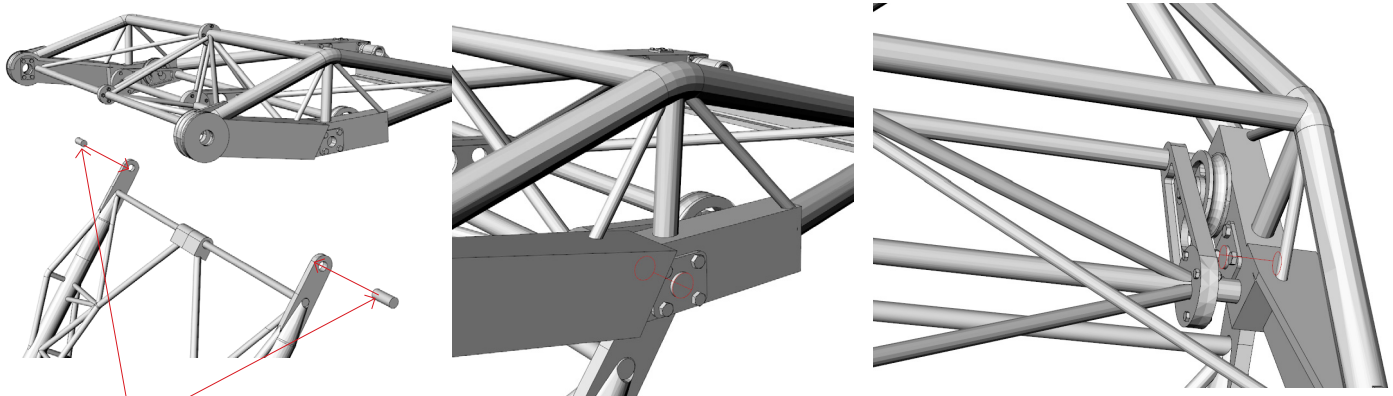

1.4mm Rod Pin/trim. Once top 20 is in place you can now fix top rod to part 15 and fix parts 15 to their final position

10

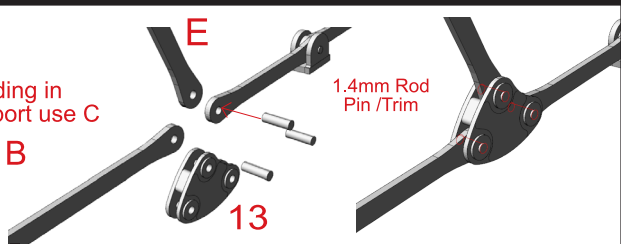
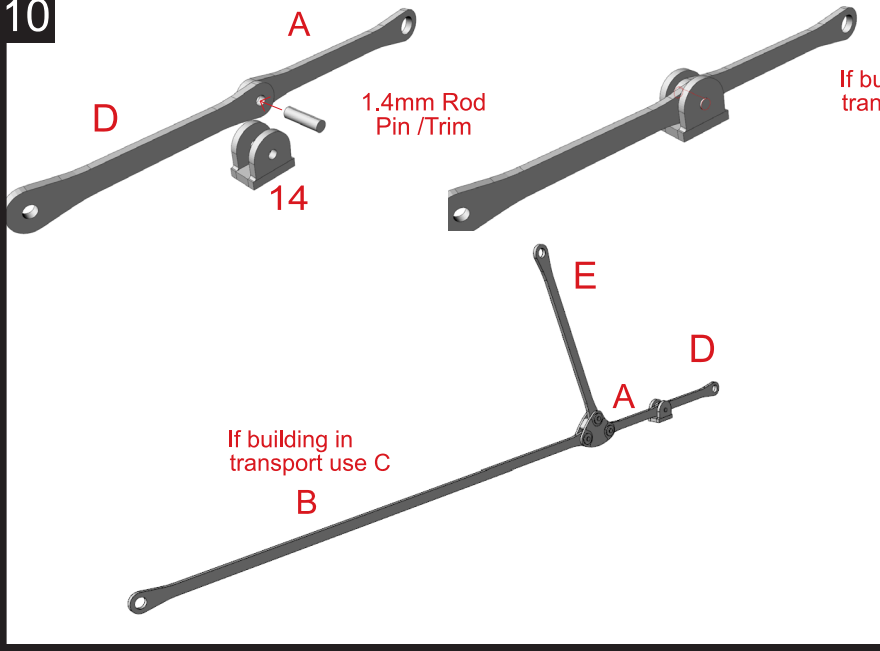

11

